



---

## Ultraviolet Microscopy: Risk versus Rewards

*Dr. Sunita Pande, Associate Professor,*

*Department of Zoology, Maharani Shri Jaya Govt. PG College, Bharatpur and Dr. Avinash Pande, Associate Professor, Department of Pathology, Govt. Medical College, Bharatpur.*

Microscopes have opened up a whole new dimension in science, By using microscopes scientists are able to discover the existence of the microorganisms, study the structure of cells, and see the smallest parts of plants, animals, and fungi. They are one of the most important diagnostic tools to examine the tissue samples. Microscopic examination confirms the laboratory tests like malaria, leukemia, Hay fever, Trypanosomiasis and many more.

Microscopes use the simple visible light refracting lenses, electrons, X rays, Ultra Violet rays and infrared rays. There are six main sub-categories of light microscopy, which include:

- I. Dark field microscopy
- II. Bright field microscopy
- III. Fluorescence microscopy
- IV. Ultraviolet microscopy
- V. Phase contrast microscopy
- VI. Differential interference contrast

In UV microscopy Ultra Violet light is used to view samples at a higher resolution than is possible with visible light. In light microscopy, shorter the wavelength of light, better is the resolution. The UV light source has a wavelength between 180-400 nm whereas the wavelength of visible light is 400 -700 nm. This shorter wavelength of Ultra violet light gives a magnification approximately double of what is possible with white light. Ultra violet microscopy offers increased contrast too as the response of the object to UV light is quite good and so it is easy to differentiate the object from its background.

The UV microscopy was developed in 20th century by German scientists Köhler and Moritz von Rohr. Since glass lenses create a hazy unclear image when used at short wavelength, Quartz lenses are used in UV microscopy. UV microscopes became most widely used for fluorescent microscopy, in which the UV rays caused the stains to fluoresce. Later on, when scientists discovered that Electron beam has even shorter wavelength than UV rays, Electron microscopes were developed.

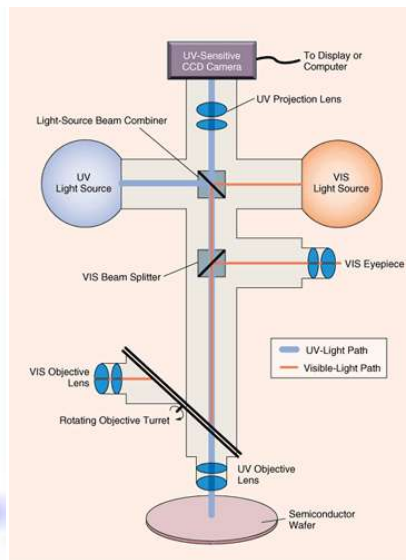

Different types of objective lenses are used in UV microscopy some of which cause Chromatic aberration. These lenses divide light into different wavelengths which have different focal points. Thus red, green and blue colours focus at different points. Besides, the lenses also cause Spherical aberrations due to their shape. So lenses are corrected for spherical and chromatic aberrations. Among variety of lenses such as achromat, semi-apochromat, apochromat and plan apochromat, the achromat lenses are most basic which focus red and blue colours to the same point and are spherically corrected for green colour. The plan apochromat lenses, the most expensive ones, are considered superior as these produce a flat image and are corrected for four colours.

Though plan apochromat objectives produce the best image, they have highest levels of UV transmission which harms the user's eyes. Exposure to UV radiation can harm the eyes and compromise vision in several ways;

- Prolonged UV exposure may cause cancer in skin surrounding eyes.
- UV exposure can cause cataract in which clouding of the lens of eyes occur. It has been established that more than 10% of cataracts are due to UV exposure.
- Extended exposure to UV light increases the risk of damage to retina which results in developing macular degeneration
- UV light from the sun can cause Pterygium which is a yellowish pink, non-cancerous growth on conjunctiva over the sclera of eye.

**Protection from UV light is possible to some extent if UV microscopy is done judiciously**

1. Enclosed beam paths should be used wherever possible.
2. Shutter **should be** closed when the source is idle.
3. Refrain from looking directly at the beam.
4. Restrict access **to** regions **using UV** sources.
5. Professionals using UV microscopy for long time should wear protective clothing to cover their arms and neck.
6. Limit exposure time to UV rays.
7. Wear protective eyewear which can block out 99 to 100 percent of UV radiation. Such glasses are available in market.